

Attachment Roller Chain

ANSI | Double Pitch | Attachment | ATT

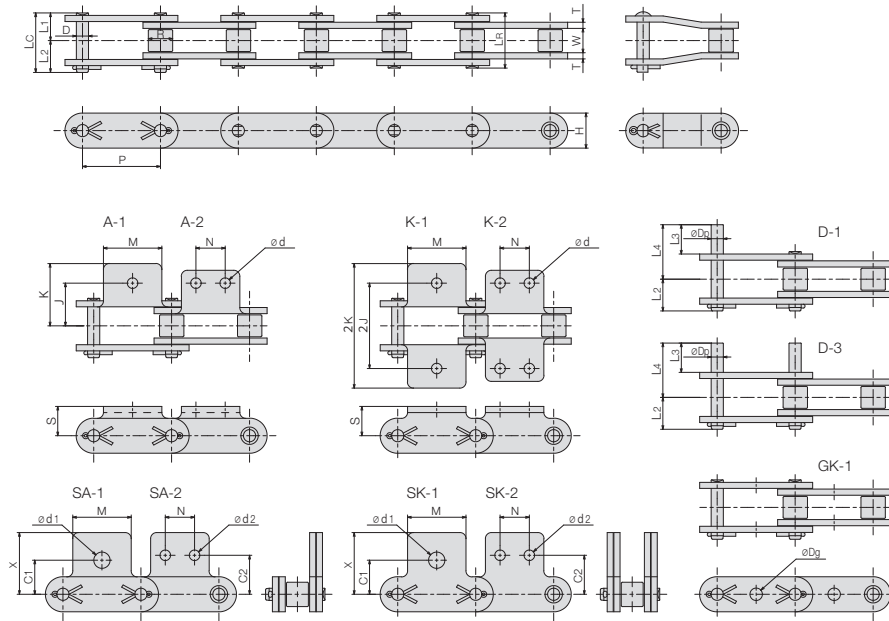

SY Chain No.	Pitch P	Dimension - mm												Average Tensile Strength kN	Average Chain Weight kg/m	
		Roller			Pin								Plate			
		Width W	Roller Type	Dia. R	Dia. D	Length										Height H
				L _R	L _C	L ₁	L ₂	L ₃	L ₄							
SY C2040	25.40	7.95	S	7.92	3.96	16.6	18.3	8.3	10.0	9.5	16.8	11.4	1.5	16.90	0.48	
SY C2042			R	15.88											0.82	
SY C2050	31.75	9.53	S	10.16	5.08	20.5	22.2	10.2	12.0	11.9	21.1	15.0	2.0	27.50	0.82	
SY C2052			R	19.05											1.26	
SY C2060H	38.10	12.70	S	11.91	5.95	28.8	31.0	14.4	16.6	14.3	27.5	17.0	3.2	40.20	1.38	
SY C2062H			R	22.23											2.08	
SY C2080H	50.80	15.88	S	15.88	7.93	36.4	38.8	17.8	21.0	19.1	35.6	22.6	4.0	68.60	2.32	
SY C2082H			R	28.58											3.36	
SY C2100H	63.50	19.05	S	19.05	9.53	42.4	46.0	21.2	24.8	23.8	43.2	28.6	4.8	107.90	3.46	
SY C2102H			R	39.67											5.64	
SY C2120H	76.20	25.40	S	22.23	11.10	52.8	57.2	26.4	30.8	28.6	53.0	34.9	5.6	151.00	4.92	
SY C2122H			R	44.45											7.87	
SY C2160H	101.60	31.75	S	28.58	14.28	67.9	73.1	34.0	39.1	38.1	69.0	47.6	7.2	257.90	8.02	
SY C2162H			R	57.15											12.77	

SY Chain No.	Dimensions - mm															Additional Weight D-1 g/pc
	M	d	N	S	X	A-1, A-2		K-1, K-2		SA-1, SK-1		SA-2, SK-2			GK-1	
						J	K	2J	2K	C1	d1	C2	d2	N	Dg	
SY C2040	19.1	3.6	9.5	9.1	19.8	12.7	19.1	25.4	38.2	11.1	5.2	13.5	3.6	9.5	4.1	0.9
SY C2042																
SY C2050	23.8	5.2	11.9	11.1	24.6	15.9	24.2	31.8	48.4	14.3	6.8	15.9	5.2	11.9	6.4	1.8
SY C2052																
SY C2060H	28.6	5.2	14.3	14.7	30.6	21.4	31.2	42.8	62.4	17.5	8.7	19.1	5.2	14.3	6.4	3
SY C2062H																
SY C2080H	38.1	6.8	19.1	19.1	40.2	27.8	40.6	55.6	81.2	22.2	10.3	25.4	6.8	19.1	8.1	7
SY C2082H																
SY C2100H	47.6	8.8	23.8	23.4	50.3	33.3	50.0	66.6	100.0	28.6	14.0	31.8	8.8	23.8	10.1	12
SY C2102H																
SY C2120H	57.2	10.5	28.6	27.8	61.1	39.7	61.9	79.4	123.8	33.3	16.0	37.3	10.5	28.6	12.1	20
SY C2122H																
SY C2160H	76.2	14.0	38.1	36.5	76.2	52.4	76.1	104.8	152.2	44.5	21.0	50.8	14.0	38.1	-	44
SY C2162H																

ANSI ダブルピッチの継手リンクは割ピン式が標準仕様です。Roller Type "S"は、標準タイプのローラです。Roller Type "R"は、キャリアタイプのローラです。Roller Type "R"は、プラスチックタイプのローラも製作可能です。

BS Single Pitch

ANSI Single Pitch

ANSI Double Pitch

ENGL. 81X

Technical Information